



National  
Defence

Défense  
nationale

C-30-108-000/ME-003

**INSTALLATION INSTRUCTION**

**MILITARY POLICE KIT INSTALLATION  
FOR  
TRUCK, UTILITY, LIGHT, 4 × 4  
MILITARY DESIGN, ILTIS CANADIAN**

(BILINGUAL)

Issued on Authority of the Chief of the Defence Staff

Contact Officer: DSVEM 5-2

OPI: DSVEM

Copyright © 1986 by DND Canada

1986-09-09

**PURPOSE**

1. To install the warning light, sirens and signs on designated Canadian Forces Military Police vehicles.

**WHEN INSTALLATION SHALL BE EMBODIED**

2. On receipt of this instruction. After installation, units shall request a VMO from DPSL 3-5 to change the Equipment Configuration Code from ECC 121501 to ECC 121527.

**INSTALLATIONS AFFECTED**

3. Warning Light, Sirens and Signs.

**EQUIPMENT AFFECTED**

4. All Trucks, Utility, Light 4 × 4, Iltis Canadian designated as Military Police vehicles.

**BY WHOM WORK SHALL BE PERFORMED**

5. a. Second or third line maintenance organizations, on request from Military Police Units.

**RESOURCES REQUIRED**

6. The following resources are required:
  - a. Manpower — the following estimated manpower resources are required:
    - ELM TECH 431 — 2.0 man-hours.
    - METALS TECH 441 — 1.0 man-hours.
    - VEH TECH 411 — 3.0 man-hours.



**NOTICE**

This documentation has been reviewed by the technical authority and does not contain controlled goods.

**AVIS**

Cette documentation a été révisée par l'autorité technique et ne contient pas des marchandises contrôlées.



National  
Defence

Défense  
nationale

C-30-108-000/ME-003

**INSTALLATION INSTRUCTION**

**MILITARY POLICE KIT INSTALLATION  
FOR  
TRUCK, UTILITY, LIGHT, 4 × 4  
MILITARY DESIGN, ILTIS CANADIAN**

(BILINGUAL)

Issued on Authority of the Chief of the Defence Staff

Contact Officer: DSVEM 5-2

OPI: DSVEM

Copyright © 1986 by DND Canada

1986-09-09

**PURPOSE**

1. To install the warning light, sirens and signs on designated Canadian Forces Military Police vehicles.

**WHEN INSTALLATION SHALL BE EMBODIED**

2. On receipt of this instruction. After installation, units shall request a VMO from DPSL 3-5 to change the Equipment Configuration Code from ECC 121501 to ECC 121527.

**INSTALLATIONS AFFECTED**

3. Warning Light, Sirens and Signs.

**EQUIPMENT AFFECTED**

4. All Trucks, Utility, Light 4 × 4, Iltis Canadian designated as Military Police vehicles.

**BY WHOM WORK SHALL BE PERFORMED**

5. a. Second or third line maintenance organizations, on request from Military Police Units.

**RESOURCES REQUIRED**

6. The following resources are required:
  - a. Manpower — the following estimated manpower resources are required:
    - ELM TECH 431 — 2.0 man-hours.
    - METALS TECH 441 — 1.0 man-hours.
    - VEH TECH 411 — 3.0 man-hours.

C-30-108-000/ME-003

- b. Downtime — 4.0 hours.
- c. Materiel Required — the following items are required:

**NOTE**

The blue light assembly (Item 1) is used on Military Police vehicles in Europe only. For Military Police in Canada, order the amber light (Item 2) and red lens (Item 3).

ITEM	STOCK NO.	DESCRIPTION	QTY
1	6220-21-250-5455 (2RL 003 134 011)	Light Assembly, warning, beacon, c/w blue lens	1
		(or)	
2	6220-99-838-5677 (2RL 003 134 131)	Light Assembly, warning, beacon, c/w amber lens (use with Item 3)	1
3	6220-21-250-5440 (9EL 852 061 021)	Lens, warning, beacon, coloured red (use with Item 2)	1
4	6350-21-250-7621 (3AG 003 399 101)	Siren Set, 1 low tone, 1 high tone	1
5	6350-21-902-5083 (5AB 003 188 011)	Control Unit, tone, siren, 24 Volt	1
6	5930-21-250-6568 (6ZE 001 759 061)	Switch, alarm, siren, 24 Volt	1
7	As per Figure 1	Spacer, 25 mm × 25 mm × 12.7 mm thk	2
8	5975-00-156-3253	Strap, tie-down, plastic	20
9	6145-00-705-6679	Wire, 14 AWG	15 (Metres)
10	As per Figure 2	Bracket, mounting, switch	1
11	5305-00-432-4201	Screw, self tapping, No. 10 × 1/2 in. long	4
12	As per Figure 14, Items C and D	Sign, Military Police, front	1
13	As per Figure 14, Items A and B	Sign, Military police, rear	1
14	As per Figure 14, item E	Bracket, sign, front	2
15	Issued with tone Control Unit	Terminal, connectors, female with locking lug	10
16	M35272 (76-1357)	Terminal, quick disconnect, female (M94223-622-134)	11
17	5940-21-875-6351 (76-1019)	Terminal, lug, 5 mm ring hole	3

ITEM	STOCK NO.	DESCRIPTION	QTY
18	5940-21-874-8112 (76-1020)	Terminal, lug, 8 mm ring hole	5
19	5940-21-863-8666 (76-1251)	Terminal, quick disconnect, plug type	2
20	5940-21-875-5770 (76-1261)	Coupler, terminal, quick disconnect	1
21	5305-12-141-9848	Screw, hex hd, M6 × 30 mm	2
22	5310-12-145-5638	Nut, self-locking, M6	2
23	5310-00-550-1130	Washer, internal tooth, B6	4
24	5305-12-141-9828	Screw, hex hd, M5 × 20 mm	1
25	5310-12-154-2147	Nut, self-locking, M5	1
26	5310-00-576-5752	Washer, internal tooth, B5	3
27	5305-00-057-9612	Screw, self-tapping, No. 8-18 × 1/2 in. long	1
28	5305-12-166-3829	Screw, pan hd, cross hd M6 × 16 mm long	4
29	5920-21-862-1959	Sleeve, insulating, elec. shrink type	1
30	2540-21-874-8469	Strap assy, w/buckle, 18 in. long	2
	2590-21-901-3826 (B 183 898 159)	Installation Kit, Warning Light, Strut, consisting of Items 31 thru 40:	1
31	M98883 (B 183 809 007 A1)	Strut, warning light	1
32	M98883 (B 183 941 429)	Socket, light, strut, screw type (HELLA 850 434 011)	1
33	M98883 (B 183 941 425)	Cap, light, strut (HELLA 096 532 001)	1
34	(B 183 971 875)	Grommet, tube, light strut	1
35	(B 311 971 913)	Grommet, vehicle body	1
36	5305-12-125-0321 (222 880 153)	Screw, oval hd, M8 × 20	2
37	5305-21-893-8820 (222 880 155)	Screw, oval hd, M8 × 12	2
38	5310-21-896-2232 (228 080 158)	Nut, hex hd, M8	2

C-30-108-000/ME-003

ITEM	STOCK NO.	DESCRIPTION	QTY
39	5310-21-893-1668 (224 780 015)	Locking Ring B8	2
40	5310-12-126-6086 (224 680 015)	Washer, lock	2
41	(M)26066ALPINE 004	Kit, letter set, sign, military police	1

#### FABRICATION OF SPACERS, BRACKET, WIRING AND SIGNS

7. The fabrication of the required items should be planned ahead, where possible, so that the installation will not be unduly delayed.

#### NOTE

When reading this instruction, it must be noted that all the numbers which are shown in brackets ( ) refer to the item numbers in the "Material Required" List in Paragraph 6c.

#### FABRICATION OF SIREN SPACERS

8. To fabricate the two spacers required to mount the two sirens, use steel stock, NSN 9510-21-108-6577, or any 1/2-inch thick stock available locally. Figure 1 provides the dimensions required. Prime and paint the spacers using olive drab paint, prior to installation.

#### FABRICATION OF SWITCH MOUNTING BRACKET

9. To fabricate the siren switch mounting bracket, use steel or bar stock NSN 9510-21-663-5051, and shape to the dimensions shown in Figure 2. Prime and paint the bracket using olive drab paint, prior to installation.

#### FABRICATION OF ELECTRICAL WIRES

10. The tone control unit (5) is issued complete with two removable plug connectors and with female wire terminals which fit and lock into the plug connectors. The terminals must be used only on the wire end which fits into the plug connector.

11. Figure 3 provides all the information necessary to fabricate the electrical wires for the installation of the warning light and sirens. To fabricate the wires, use 14 AWG wiring, NSN 6145-00-705-6679 (9).

12. Fabricate each wire using the connectors and length of wire shown. Identify each wire by tagging each wire end with the numbers shown. When fabricating wire number 31B do not connect terminal (15) before splicing together with existing wire 25a of the horn relay. This connection is made at the horn relay and a new terminal (15) should be used. When fabricating wire 84A which fits inside the strut, coat the bare end with solder to ensure a good contact.

#### MILITARY POLICE SIGNS

13. To fabricate the military police signs, use aluminum bar stock, NSN 9530-21-664-0195, approximately 2500 mm long. For details, see Figure 14 and Paragraphs 21 and 22.

#### ASSEMBLING WARNING LIGHT STRUT

14. To assemble the warning light strut, proceed as follows:

- a. Install the rubber grommet (34) into the existing hole in the side of the strut (31).
- b. Insert fabricated wire 84A, with the bare end through the rubber grommet (34) in the strut (31) and work to the top inside the strut.

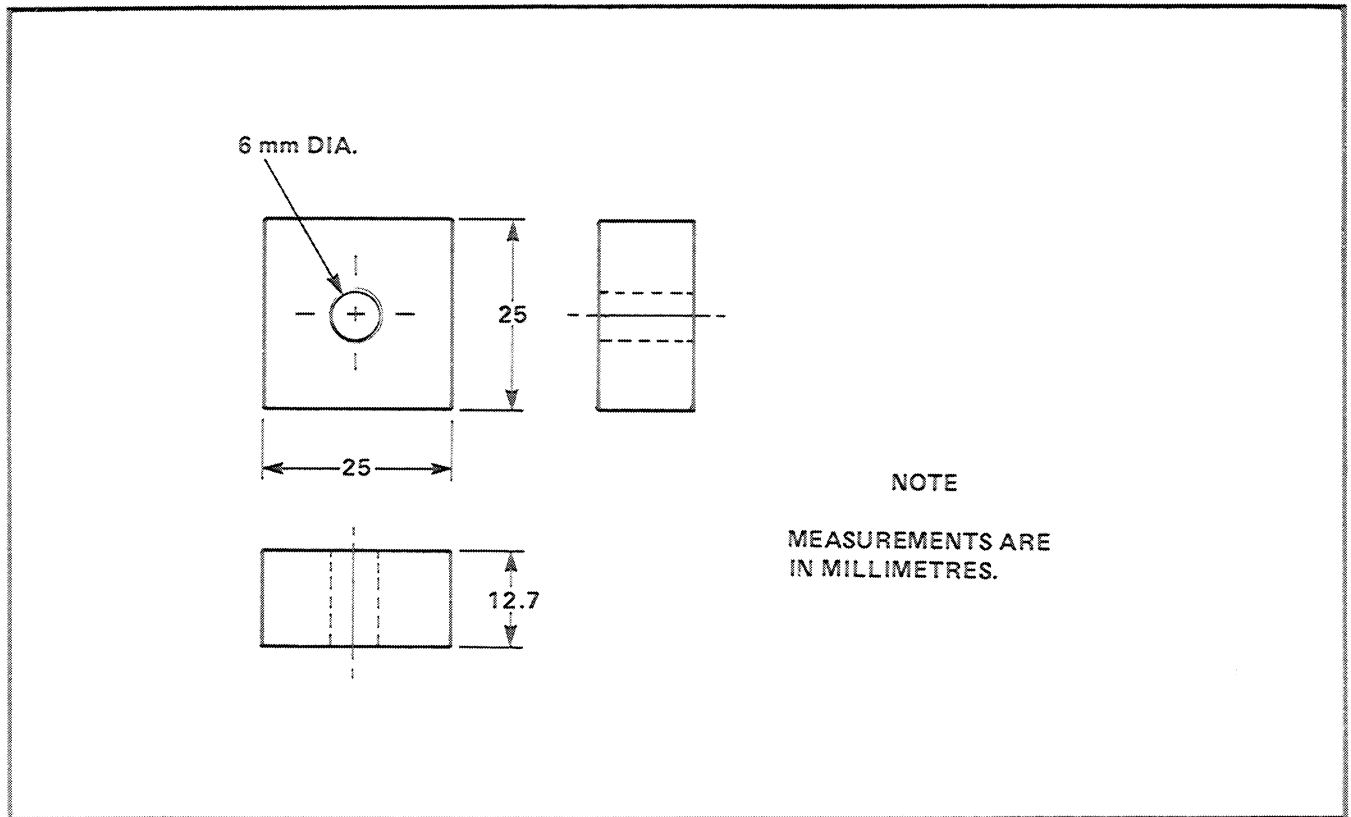

Figure 1 Dimension of Siren Spacer

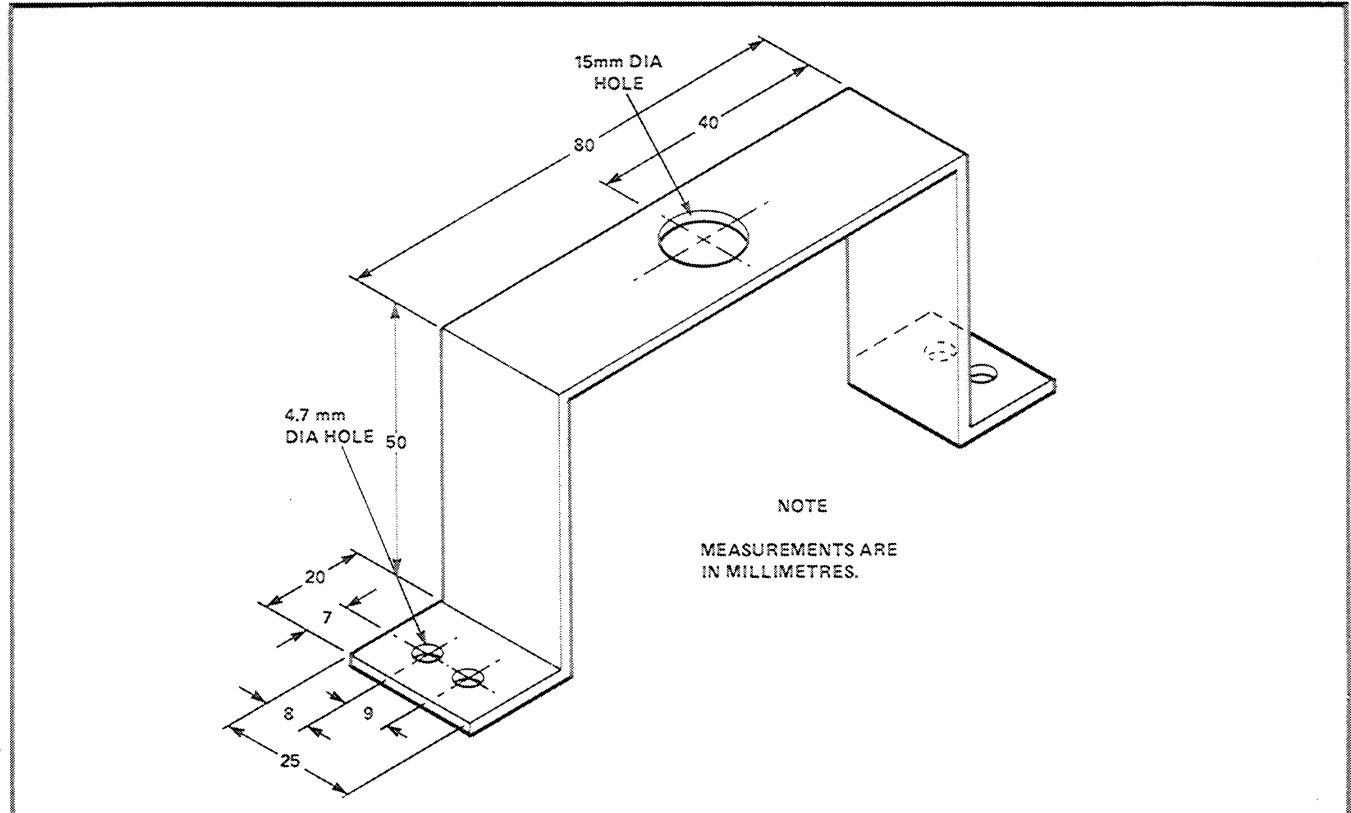

Figure 2 Fabrication of Siren Switch Mounting Bracket

Wire Number	Para 6c Item No.	Wire Length and Wire Identification Tags	Para 6c Item No.	REMARKS
86	15	 1900 mm	16	CONTROL TO SWITCH
84B	15	 1900 mm	16	CONTROL TO SWITCH
84	15	 1900 mm	16	CONTROL TO SWITCH
71	15	 1900 mm	16	CONTROL TO CIRCUIT BREAKER 25
84A	15	 1800 mm	19 & 20	CONTROL TO STRUT
84A	19	 1100 mm	BARE WIRE	INSIDE STRUT
31B	15	 1100 mm SPLICE INTO 25a ON HORN RELAY	16	SWITCH TO HORN RELAY
72	17	 900 mm 100 mm	16 16	SWITCH TO CIRCUIT BREAKER 25
31/1	18	 900 mm	16	SWITCH TO VEH GRND
71A 71B	15	 400 mm	16	CONTROL TO SIRENS
88	15	 150 mm	18	CONTROL TO GRND
71A 71B	18	 100 mm	16	SIREN TO GRND
32	18	 200 mm	17	STRUT TO GRND

Figure 3 Fabrication of Electrical Wiring

- c. Loosen the set screw in the light socket (32), insert the wire bare end and tighten the set screw securely.
- d. Screw the socket (32) into the top of the strut (31), making sure to turn the wire with the socket so as not to twist or damage the wire.
- e. Fit and install the cap (33) onto the strut (31) and socket (32).

#### INSTALLATION OF WARNING LIGHT STRUT

15. To install the warning light strut, proceed as follows:
  - a. See Figure 4. Measure and scribe the warning light electric wiring hole location on the left side of the vehicle.
  - b. Using a 12.7 mm (1/2 in) drill bit, drill the scribed hole through the outer layer of the vehicle body (shell) only. If necessary, use a drill bit depth gauge so as not to perforate the inner layer of the body.
  - c. Install the rubber grommet (35) into the drilled hole.
  - d. Using a screwdriver, disconnect and remove the vehicle light switch panel from the dash to provide access behind the instrument panel.
  - e. From inside the vehicle, insert the smaller terminal of the fabricated strut ground wire (32) through the existing hole in the inner body reinforcement and the grommet (35), leaving the wire to hang loose.
  - f. Using a phillips head screwdriver, remove and discard the two screws from the left side mirror bracket.
  - g. Using a self-tapping screw (27) with internal tooth washer (26) secure wire (32) to the light strut (31).
  - h. Insert the strut wire 84a through the grommet (35) in the vehicle body and through the existing hole in the inner body reinforcement.
  - j. Fit the light strut (31) upper support bracket over the mirror bracket and secure using the two screws (37) with lockwashers (40).
  - k. Using the lower strut bracket as a template and using an 8 mm drill bit, drill the two holes through the vehicle fender skirt.

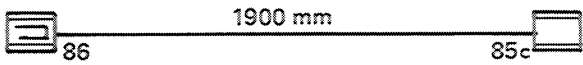
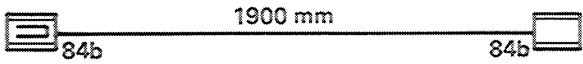
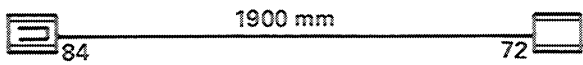
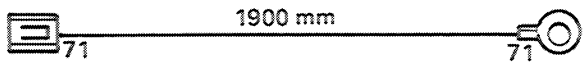
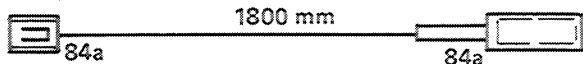
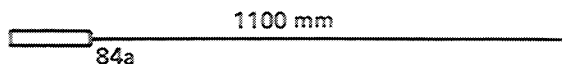
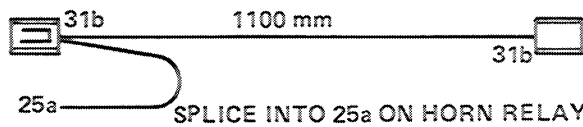
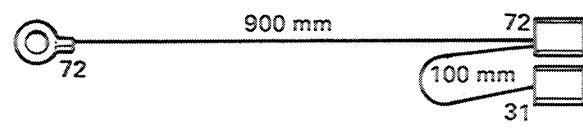
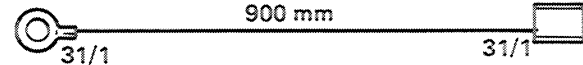
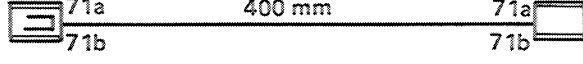
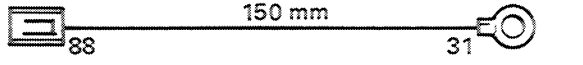
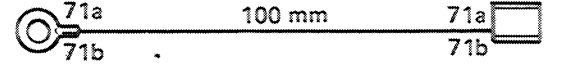
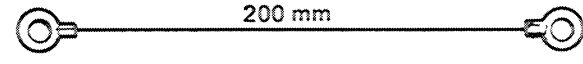
#### NOTE

Before drilling the holes, make sure that the strut is at least 6 mm (1/4 in) away from the windshield frame.

- m. Secure the lower bracket using the screws (36), lock rings (39) and nuts (38).
- n. If required, remove the cap (33) and install the warning light (1 or 2) on the strut (31). Also see Paragraph 19.

#### SIREN SWITCH INSTALLATION

16. The siren switch is mounted on the vehicle dashboard under the instrument panel. To install the switch, proceed as follows:
  - a. From the new switch, remove the knob, mounting nut, switch plate and existing bracket. Discard the bracket.
  - b. Install the switch into the large hole in the fabricated bracket (10), reinstall the switch plate and secure using the previously-removed nut. Reinstall the switch knob.
  - c. See Figure 5. Fit the switch bracket under the instrument panel, on the dashboard, so the leg of the

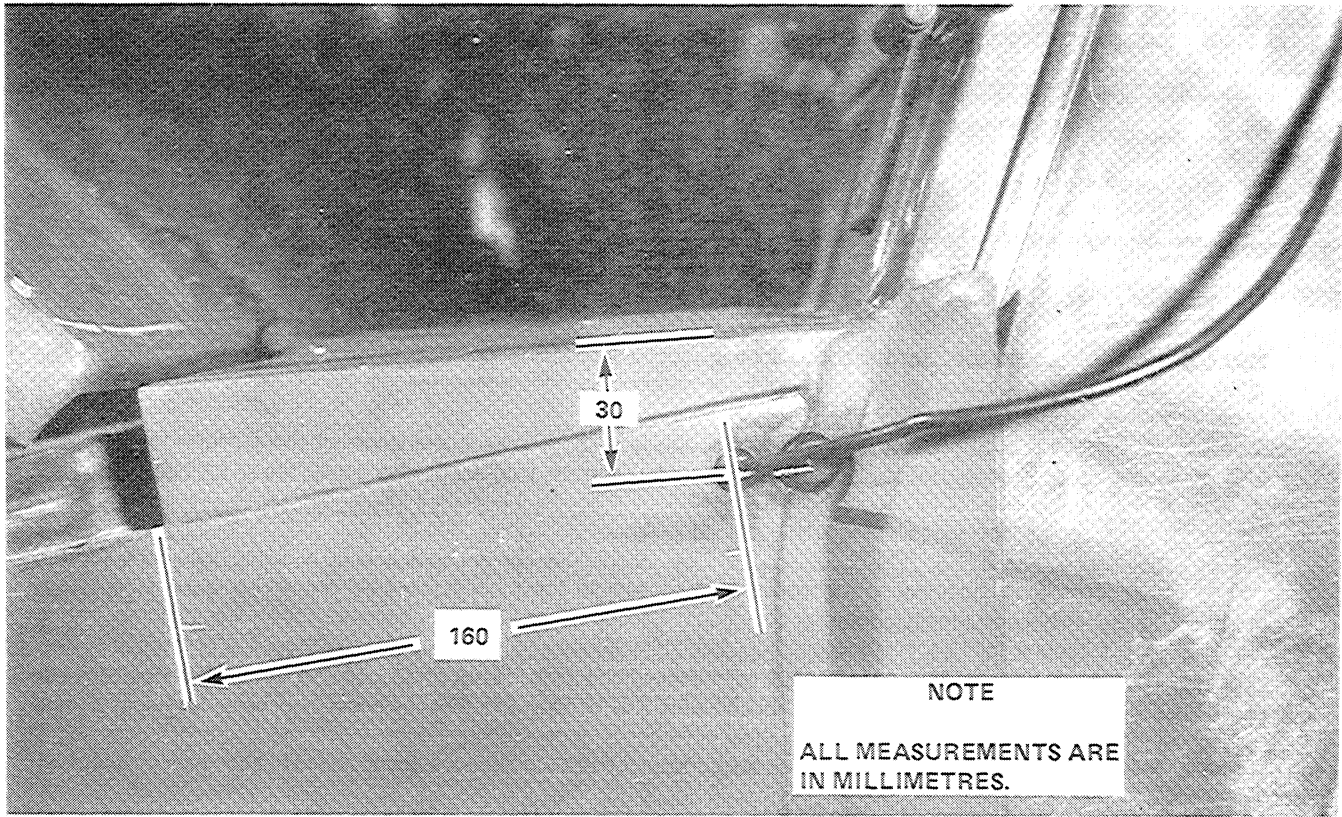

Figure 4 Measuring Hole for Warning Light Wiring

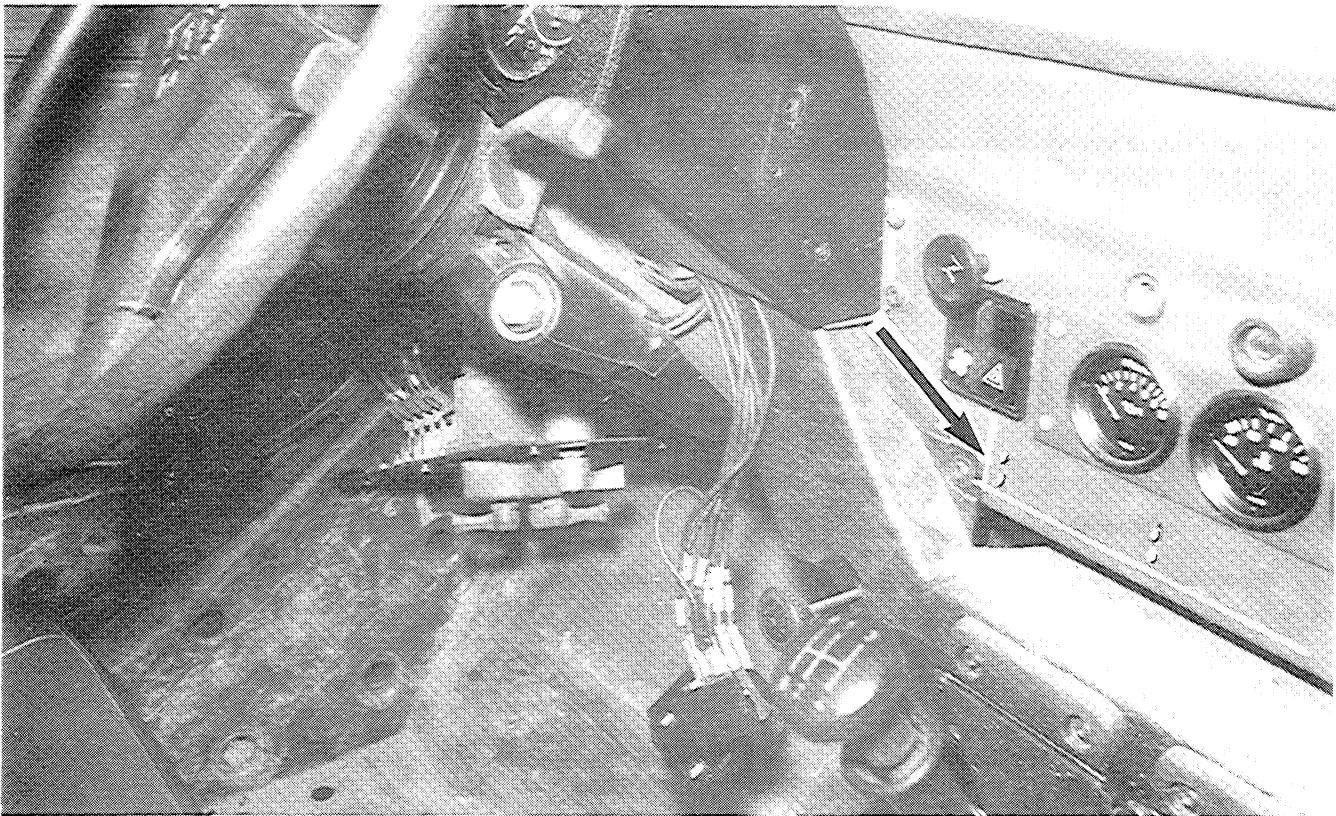

Figure 5 Locating and Drilling Switch Bracket Holes

bracket butts against the heater duct screw bracket (see arrow) and is approximately 15 mm from the bottom of the dashboard.

- d. Using a No. 30 drill size and while holding the switch bracket as a template, drill through the four holes in the bracket and through the dashboard.
- e. Secure the switch bracket to the dashboard using the self-tapping screws (11).

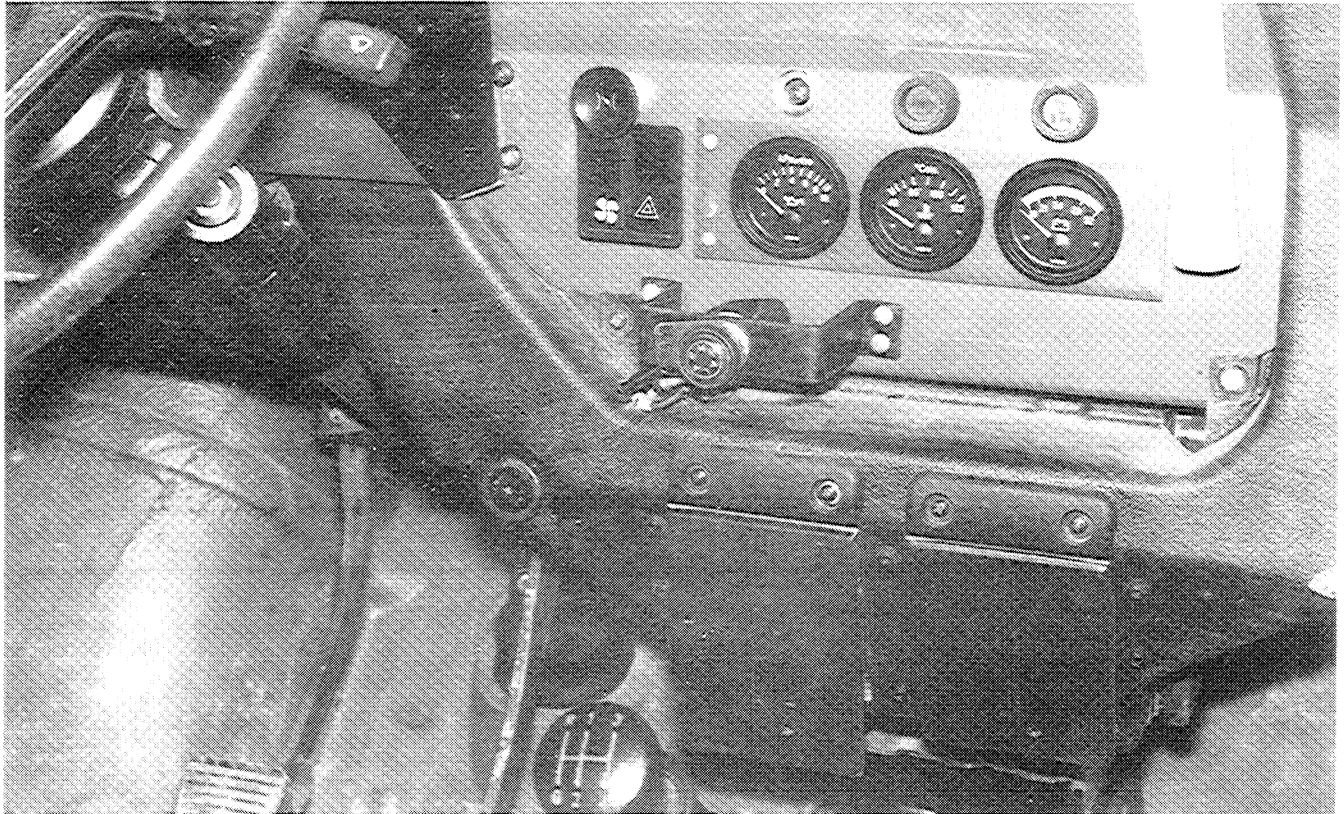

Figure 6 Installation of Siren Switch and Bracket

### INSTALLATION OF SIRENS

17. The two sirens (4) are installed in the vehicle left side headlight compartment. To install the sirens, proceed as follows:
  - a. See Figure 7. Measure and scribe the two hole locations on the rear inner wall inside the headlight compartment.
  - b. Using a 6 mm drill bit, drill the two holes as shown and clean the paint from around the holes to provide a good ground.
  - c. On a screw (21), assemble an internal tooth washer (23) and ground wire 71a. Insert the assembled screw through the low tone siren (4) mounting bracket and fit a spacer (7).
  - d. With the siren down in the compartment, install the assembled screw through the outer drilled hole and secure using a second internal tooth washer (23) and self-locking nut (22).
  - e. Connect the ground wire 71a to the siren ground terminal.
  - f. Install the second siren as in subparagraphs c, d and e above, using the 71b ground wire and high tone siren (4).
  - g. Figure 8 shows installation of sirens.

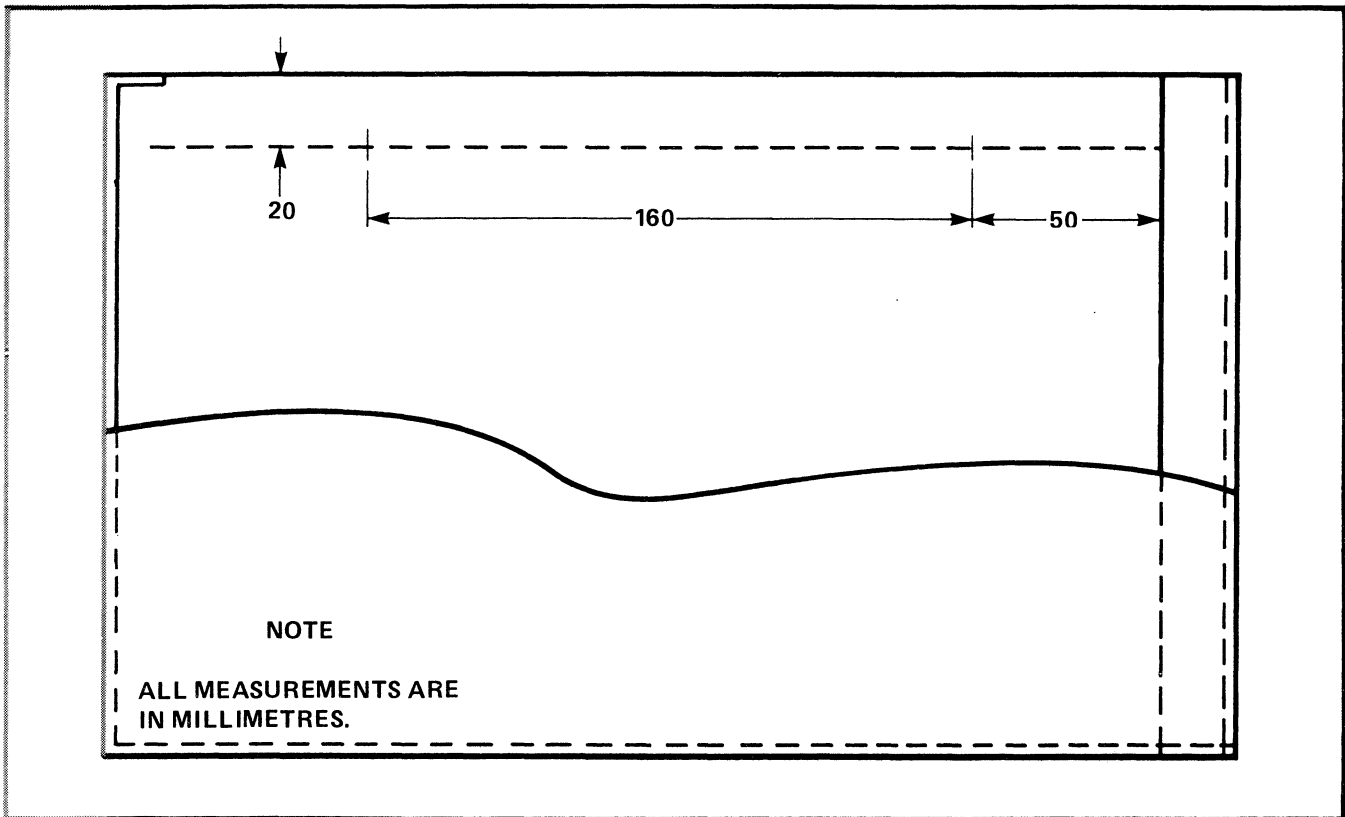

Figure 7 Measuring and Drilling Siren Mounting Holes

## INSTALLATION OF WIRING

18. To install the previously fabricated wiring, proceed as follows:
  - a. Gather the tone control unit terminal connectors (15) of assembled wires 71, 84, 84A, 84B and 86. From inside the vehicle, insert the terminal connectors and wires through the vehicle fire wall immediately beside the vehicle left front wiring harness; see arrows in Figure 9.
  - b. Run the wires along beside the vehicle left wiring harness and pass the wires through the harness grommet at the left headlight compartment.

### NOTE

The wire terminal numbers are printed on the side of the tone control unit (see Figure 10). Make sure the wires are installed into the correct location in the control unit plug connector. Also use wiring diagram in Figure 11 when making the hook-up.

- c. See Figure 10. Place the tone control unit (5) in convenient location and insert each numbered wire terminal connector into the corresponding numbered socket in the control unit plug connectors, ensuring that the terminals are locked in place.
- d. At the opposite end of the wires, route wire 84a to the light strut and using the coupler (20), connect to wire 84a leading from the strut (31).
- e. Route and connect wire ends marked 72, 84b and 85c to the corresponding numbers on the siren switch.
- f. Route wire 71 to the vehicle circuit breaker board. Remove the screw which secures wire number 25 to the horn circuit breaker. Install and secure both eye terminals of wires 71 and 72 together with wire number 25 on the circuit breaker.

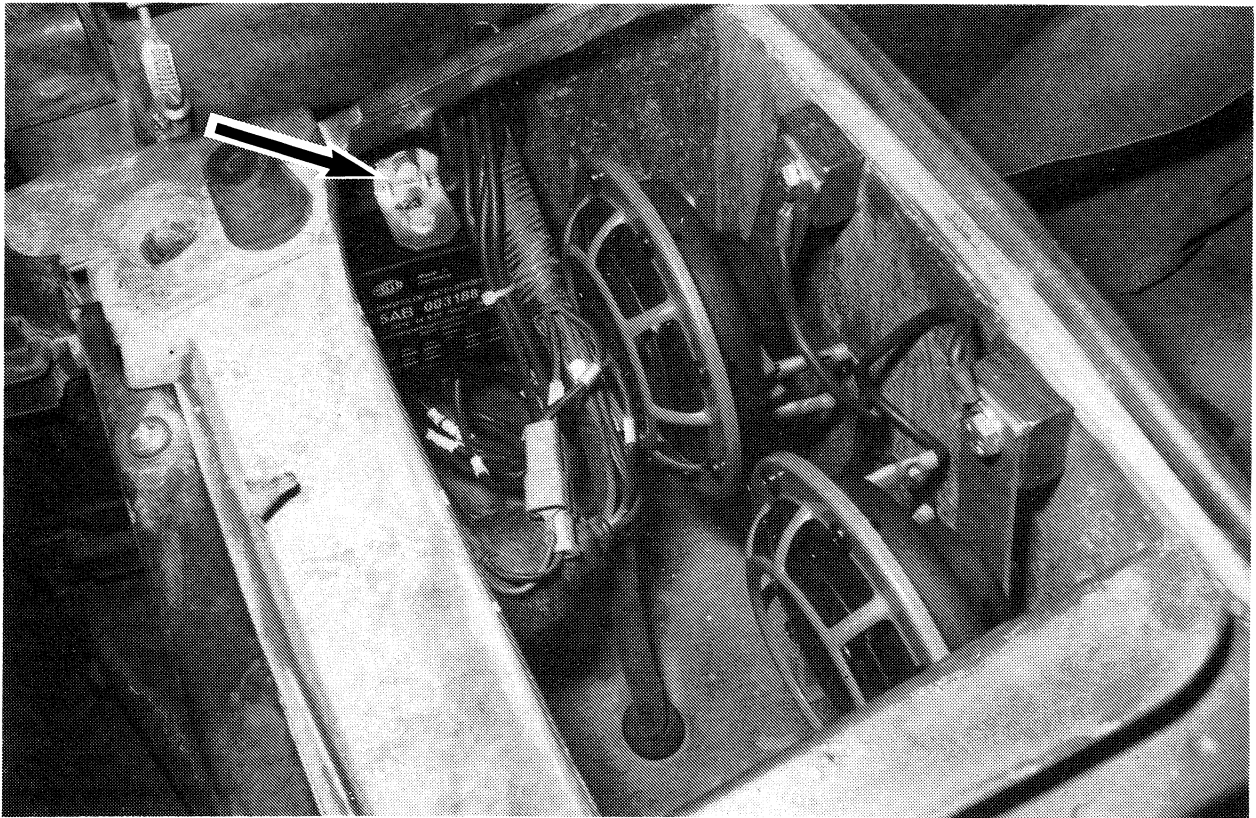

Figure 8 Sirens Installed in Headlight Compartment

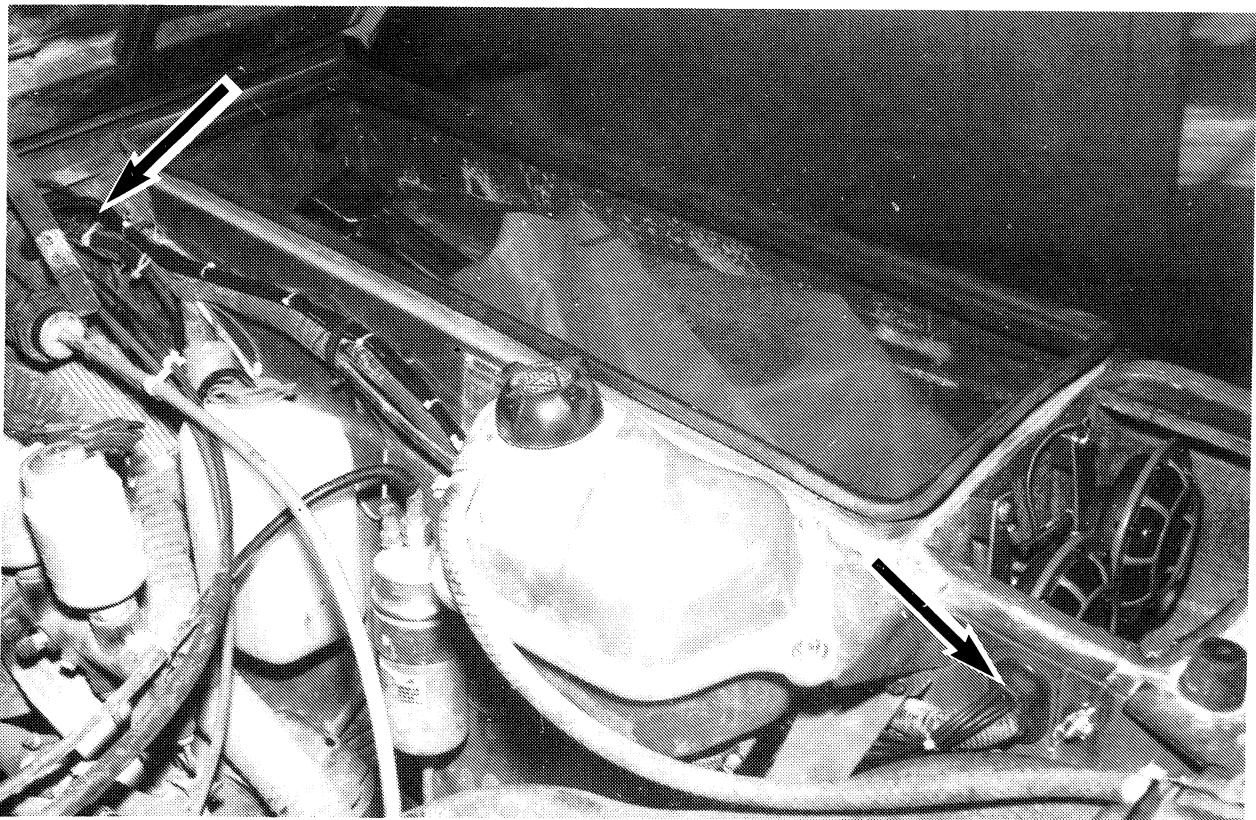

Figure 9 Installation of Wiring

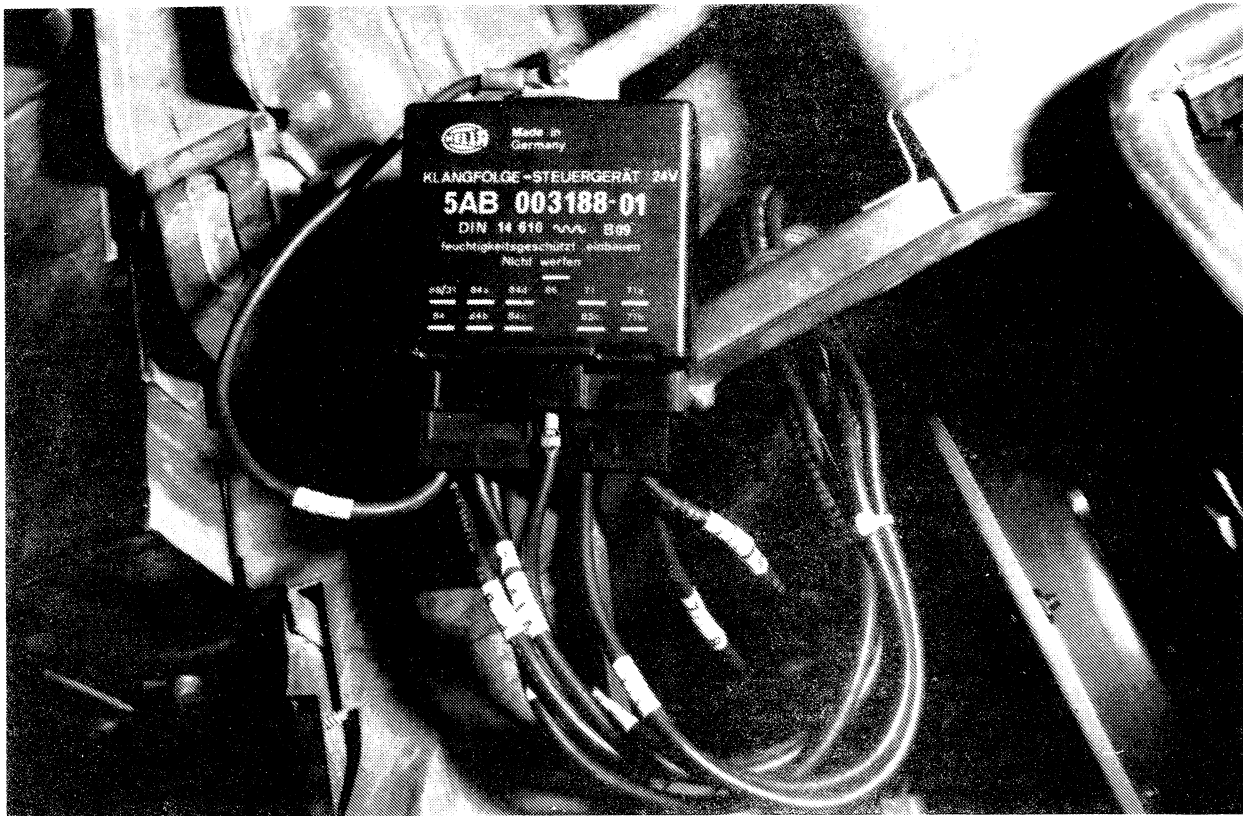

Figure 10 Wires Installed into Tone Control Unit

- g. Connect the opposite end of wire 72 and jumper wire 31 to the respective numbers on the switch.
- h. Connect terminal (16) of wire 31b to 31b on the switch. At the horn relay, pull wire 25a from the relay socket and remove the old terminal from the wire end. Splice both wires 31b and 25a together using a new terminal (15). Plug the terminal into the socket of the horn relay.
- j. Connect the eye terminal of wire 31/1, together with strut ground wire 32, to the vehicle ground post (see Figure 12). Connect the opposite end of wire 31/1 to the siren switch.
- k. Plug the terminals (15) of wires 71a and 71b into the corresponding numbered sockets in the tone control unit. Plug opposite end of wire 71a to the LOW siren terminal and of wire 71b to the HIGH siren terminal.
- m. On wire 88 plug the terminal (15) into socket 88 on the tone control unit. Install the control unit inside the headlight compartment (see arrow, Figure 8) to fit the existing screw hole on the engine compartment wall. Make sure the paint is cleaned from around the screw hole.
- n. Install an internal tooth washer (26) and the ground wire 88 on screw (24). Fit the screw through the control unit mounting bracket and secure to the engine compartment wall using a second internal tooth washer (26) and self-locking nut (25).
- p. Gather the five wires which run along the light harness in the engine compartment and tie them together every 3 or 4 inches using the tie-down straps (8) (see Figure 9). Also secure the installed wiring under the dash as necessary.
- q. Check the completed wiring hook-up and test the light and siren operation.

#### MILITARY POLICE WARNING LIGHT (CANADA)

19. The Military Police in Canada use a red warning light. When receiving the amber light (Item 2) and red lens (Item 3), replace the amber lens with the red lens. Tag the amber lens as 6220-12-166-9943, Dome, halogen rotating beacon, amber, and return to Supply. The amber lens is required for other vehicles.



## TESTING LIGHT AND SIRENS FOR OPERATION

20. On completion of installation, test the operation of the light and sirens as follows:

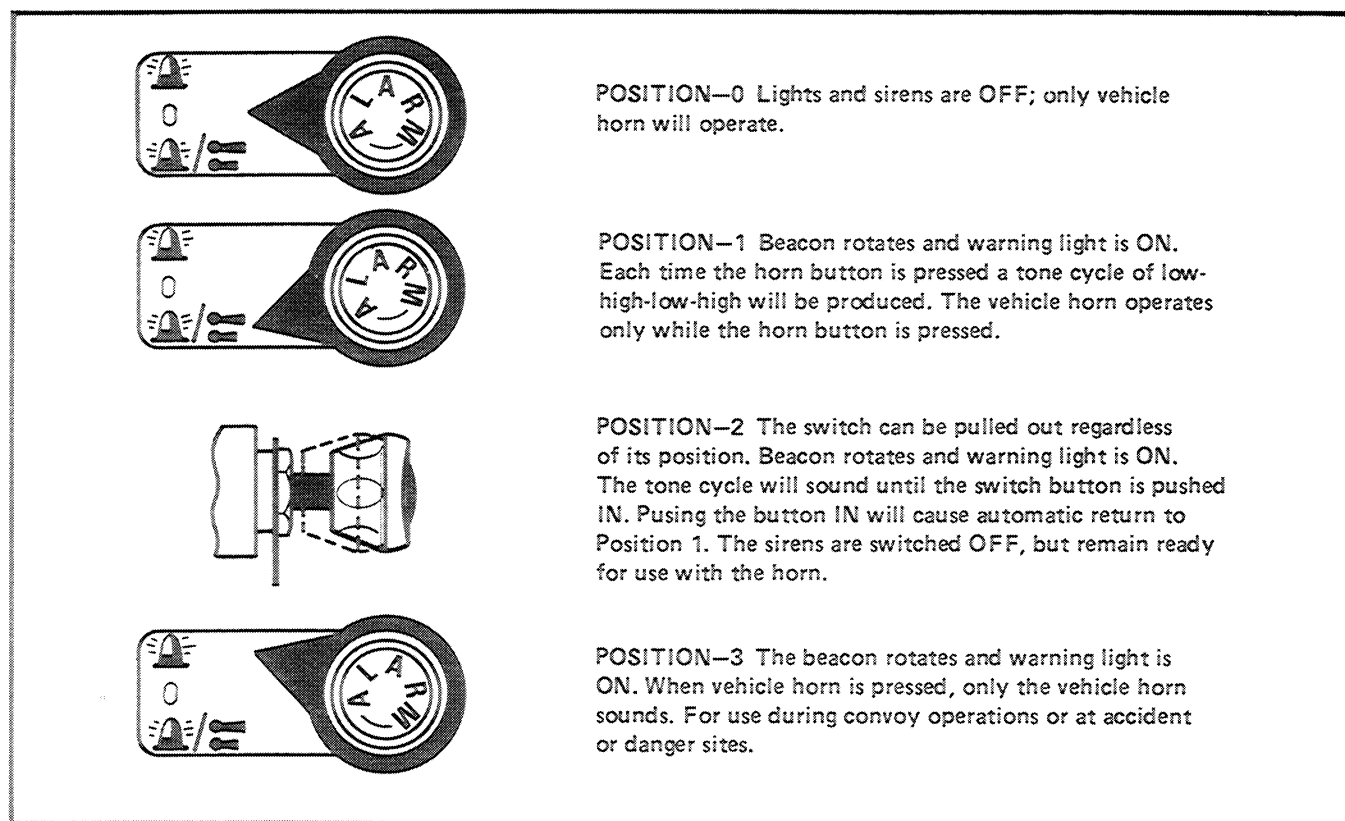

Figure 13 Testing of Light and Sirens

## FABRICATION OF MILITARY POLICE SIGNS

21. See Figure 14. The military police signs are made so they are reversible. The rear sign, views "A" and "B", is secured using the vehicle canvas cover straps on each side of the vehicle. When the canvas cover is removed, the sign is secured to the upper roll bar, immediately behind the front seats. The front sign, views "C" and "D", is secured under the vehicle windshield using two mounting brackets "E".

22. To fabricate the military police signs, see Figure 14 and proceed as follows:

- a. Cut the bar stock to the lengths as shown and grind off sharp edges and round the corners.
- b. Measure and drill the holes in the rear sign and sign brackets to the drill sizes shown.
- c. Prime and paint the two brackets (Item E, Figure 14) using primer 1-GP-132 and infrared olive drab paint 503-321.
- d. cut two pieces of insulating sleeve (29) and heat shrink onto the open end (opposite holes) of the bracket.

### NOTE

Where the insulating sleeve is not available, wrap black electrical tape around the end of the brackets.

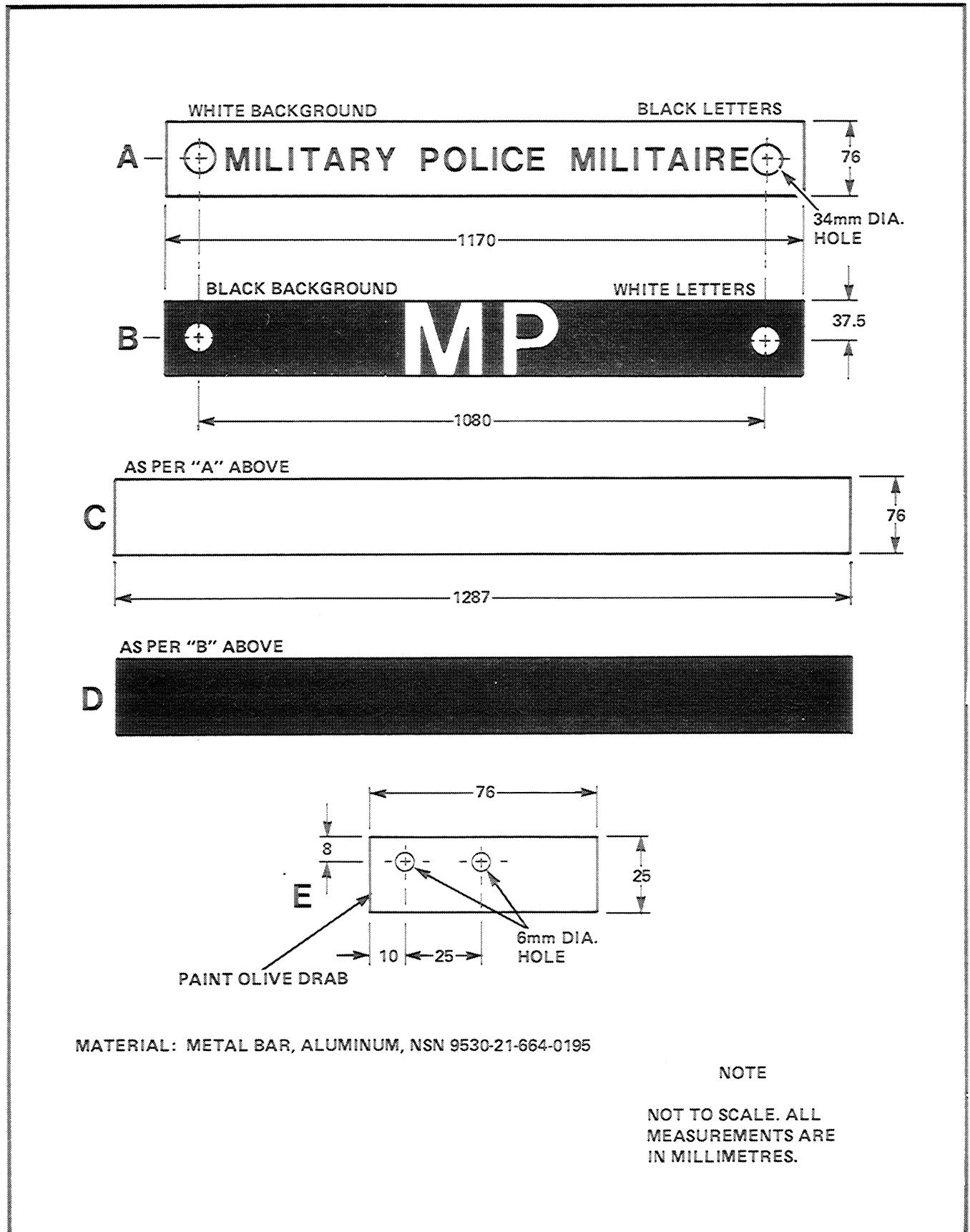

Figure 14 Fabrication of Military Police Signs

C-30-108-000/ME-003

- e. Before installing the reflective tape sheeting, clean the aluminum surfaces as follows:
- (1) Wash the surface with detergent and water.
  - (2) Saturate clean paper towelling with lacquer thinner and wipe the surfaces.
  - (3) Dry the surfaces with lint-free paper towelling before the solvent evaporates from the surface.



The application surface must be washed, dried, lacquer-wiped and dried. If necessary, let dry overnight. Where the aluminum surface is badly pitted or oxidized, a commercial acid brightener solution should be used.

**NOTE**

Other available surface cleaners are xylol, 3M wax remover 8984, or Dupont solvent cleaner 3919S.

- f. From the letter set kit (41) remove the two reflective tape sheets, with installed letters "MILITARY POLICE MILITAIRE".
- g. Peel off the reflective tape backing, centre and install the tape on one side of each sign.
- h. On the opposite side of each sign, repeat Subparagraph g. above with the MP decals.

**INSTALLATION OF MILITARY POLICE SIGNS**

23. To install the military police signs, proceed as follows:

**NOTE**

All reference numbers shown in brackets ( ) refer to the Item Number in Paragraph 6c.

- a. See Figure 15. At each side of the vehicle windshield, remove and discard the two upper screws which secure the windshield frame to the vehicle body.
- b. Place the front sign (12) against the windshield frame and secure the sign using the two fabricated brackets (14) and new screws (28).
- c. See Figure 16. At the rear of the vehicle, unlace the vehicle canvas cover. Fit the cover straps through the holes in the fabricated rear sign (13) so the ends of the sign will fit under the corner canvas, as shown. Retighten the cover straps.
- d. See Figure 17. When the vehicle canvas cover is removed, secure the rear sign (13) to the rear of the vehicle upper roll bar as shown, using the two straps (30).



Figure 15 Installation of Front Sign Under Windshield



Figure 16 Rear Sign Installed on Rear of Vehicle

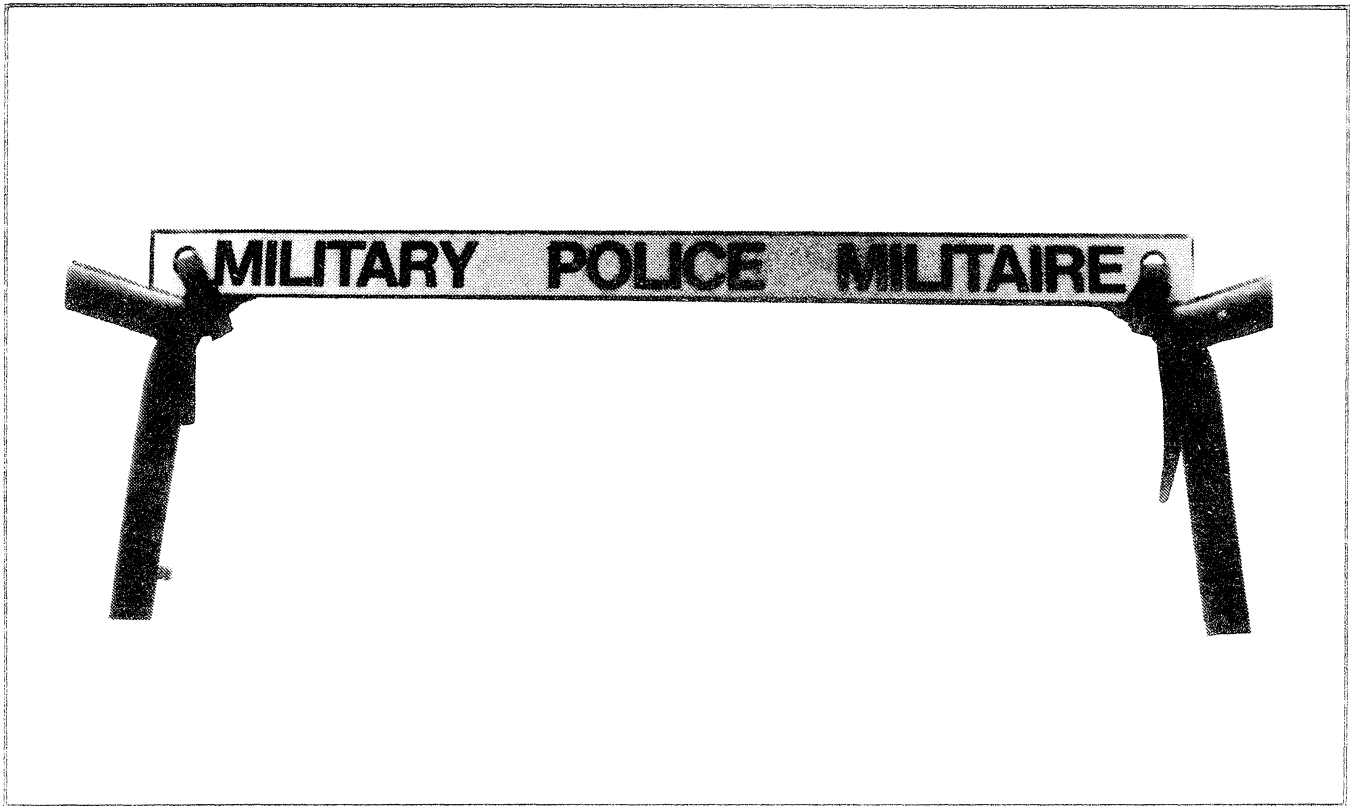

Figure 17 Rear Sign Installed on Vehicle Roll Bar